



The competence brand for energy saving systems

up to 24 kW
now with high efficiency pumps
class A and coated heating water
heat exchanger

Gas fired condensing boilers ComfortLine



Wall mounted gas fired condensing boilers CGB / CGB-K
Gas fired condensing centres CGW / CGS
Gas fired condensing solar centres CSZ

NEW!
Gas fired condensing
solar centre CSZ



TESTSIEGER
Stiftung
Warentest
test
GUT (1,6)
Gasheizzentrale
CGS-20/160
...
Ausgabe 6/2006



Gas fired condensing boilers

ComfortLine

Benefits of the WOLF gas fired condensing boilers up to 24 kW CGB / CGB-K / CGW / CGS



Pivoting heat exchanger

- Gas fired condensing boilers, sealed combustion chamber, for open and balanced flue operation
- Certified with the DVGW quality symbol; tested in accordance with German and European Directives; extremely clean combustion
- High standard efficiency up to 110% (Hi) / 99% (Hs) for the best possible energy utilisation
- Meets the requirements for the „Blue Angel“ certificate of environmental excellence to RAL-UZ 61 when operated with natural gas
- Premix burner for natural gas E, LL and LPG
- As standard with expansion vessel and three-stage heating circuit pump or modulating high efficiency pump class A; no mechanical switch in the heating water
- Heating water heat exchanger can be pivoted for easy cleaning without having to drain off the heating water
- Coated heating water heat exchanger when combined with modulating high efficiency pump class A.
- Easy installation, operation and maintenance through convenient access to all components
- Flue gas test port accessible from outside; the equipment does not need to be opened
- 2 year warranty

CGB-11, -20, -24 wall mounted gas fired condensing central heating boilers



Wall mounted gas fired condensing central heating boiler with optional connection of a DHW cylinder, e.g. CSW-120

- Modulation range for flow/return 50/30 °C:

CGB-11	from 3.6 to 10.9 kW
CGB-20	from 6.1 to 20.5 kW
CGB-24	from 7.8 to 24.8 kW
- Booster output during cylinder heating:

CGB-11	14.6 kW
CGB-20	22.9 kW
CGB-24	27.6 kW

CSW-120 DHW cylinder

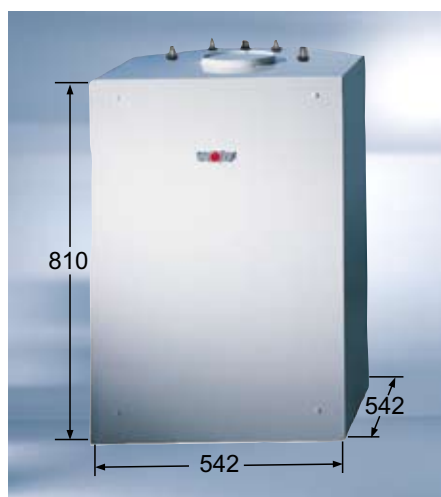

- Connections R 3/4" for flow, return, cold water, hot water and DHW circulation as well as the cleaning aperture at the top of the cylinder for easy connection and cleaning
- Powder-coated white (RAL 9016) casing
- CFC-free thermal insulation all around the cylinder, applied directly to the cylinder surface, highly effective and low heat losses
- Corrosion protection through enamelled cylinder interior and indirect internal coil to DIN 4753, part 3
Additional corrosion protection through magnesium anode integrated into the inspection and cleaning aperture
- Indirect internal coil with large heat exchanger surface area for short heat-up times
- High constant DHW output
- Drain R 1/2" at the front, incl. drain valve and hose connection
- Adjustable feet
- 5 year warranty

Gas fired condensing boilers ComfortLine

CGB-K-20, -24 wall mounted gas fired condensing boilers for DHW and central heating

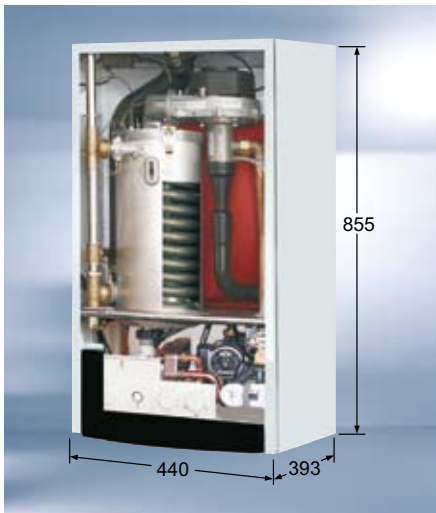

Wall mounted gas fired condensing boilers for DHW and central heating with integral stainless steel DHW heat exchanger

- Modulation range for flow/return 50/30 °C:

CGB-K-20	from 6.1 to 20.5 kW
CGB-K-24	from 7.8 to 24.8 kW
- Booster output for DHW heating:

CGB-K-20	22.9 kW
CGB-K-24	27.6 kW
- Wall mounted combi boiler easily retrofitted - optionally without cylinder or with cylinder CSW-120

CGW-11/100, -20/120, -24/140 gas fired condensing centres with high performance stainless steel stratification cylinder

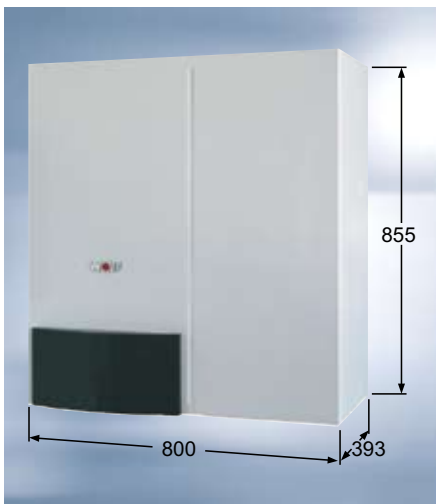

Wall mounted gas fired condensing centre, comprising a wall mounted gas fired condensing boiler with a stainless steel DHW heat exchanger and a stainless steel stratification cylinder in modular design

- Modulation range for flow/return 50/30 °C:

CGW-11/100	from 3.6 to 10.9 kW
CGW-20/120	from 6.1 to 20.5 kW
CGW-24/140	from 7.8 to 24.8 kW
- Booster output for the stratification cylinder:

CGW-11/100	14.6 kW
CGW-20/120	22.9 kW
CGW-24/140	27.6 kW
- Integral convenient DHW heating, better than a DHW cylinder with 100, 120 or 140 l capacity

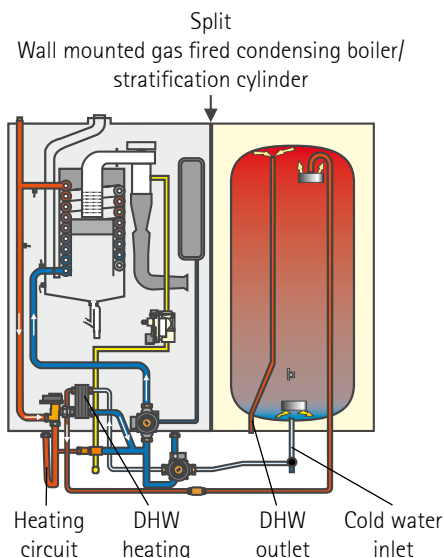

- „DHW turbo“ with a new routing and distribution system for hot and cold water inside the stratification cylinder ensure a calm, radial water distribution for excellent DHW performance (patent applied for)
- Hot water always available - even after filling a bath
- High savings in operating costs through efficient DHW heating and innovative insulation technology (patent applied for)
- Cylinder heating with return control for the highest energy efficiency (utilisation of condensing technology)
- Compact layout as condensing boiler and stratification cylinder for the lowest assembly and installation costs
- Gas fired condensing centre, fully wired and hydraulically ready to connect
- Can be split for easy handling and installation into two modules of 28 and 42 kg respectively
- The following accessories are available to ensure a quick and clean installation:
 - Connection set DHW with pressure reducer for unfinished / finished walls
 - Connection set DHW without pressure reducer for unfinished / finished walls
 - DHW circulation set
 - Solar heating connection set
 - Pipe cover

Gas fired condensing boilers

ComfortLine

CGS-20/160, -24/200 gas fired condensing centres with stainless steel DHW heat exchanger and enamelled steel stratification cylinder

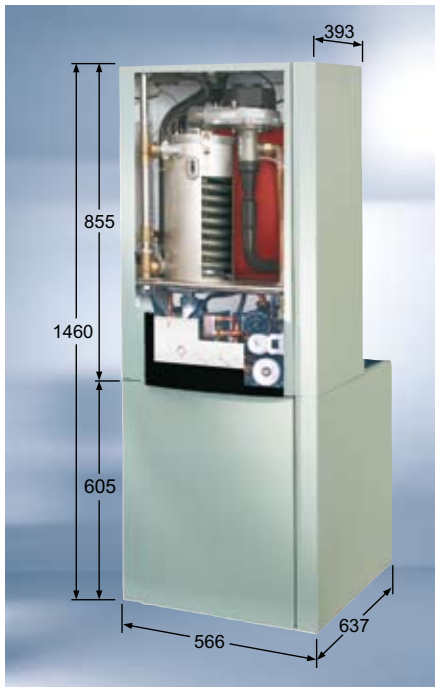

Gas fired condensing centre, comprising a wall mounted gas fired condensing boiler with a stainless steel DHW heat exchanger and a stratification cylinder in modular design

- Modulation range for flow/return 50/30 °C:

CGS-20/160	from 6.1 to 20.5 kW
CGS-24/200	from 7.8 to 24.8 kW
- Booster output for DHW heating:

CGS-20/160	22.9 kW
CGS-24/200	27.6 kW
- The „Turbo-stop system“ (patent applied for) provides a convenient DHW heating inside the stratification cylinder corresponding to that of a DHW cylinder with 160 or 200 l capacity
- Cylinder heating with return control for the highest energy efficiency through the effective utilisation of condensing technology (patent applied for)
- Filling a bath tub with 200 l of hot water at 45 °C only takes 10 or 8 minutes respectively
- 16 or 14 minutes later, 90 l DHW are available again at 60 °C
- High performance factor $N_L = 2.1$ or 2.5
- Compact design as condensing boiler with stratification cylinder. Can be split for easy installation into two modules of 52 and 47 kg respectively
- The following accessories are available to ensure a quick and clean installation:
 - Connection set with flexible stainless steel pipes; insulation to EnEV for heating flow/return, hot/cold water and gas; suitable for installation on unfinished and finished walls (see Fig. below)
 - Solar heating connection set for the additional control of a solar cylinder
 - DHW circulation set to EnEV incl. DHW circulation pump
 - Drain outlet kit with triple hose retainer
 - Pipework cover with variable knock-out entries

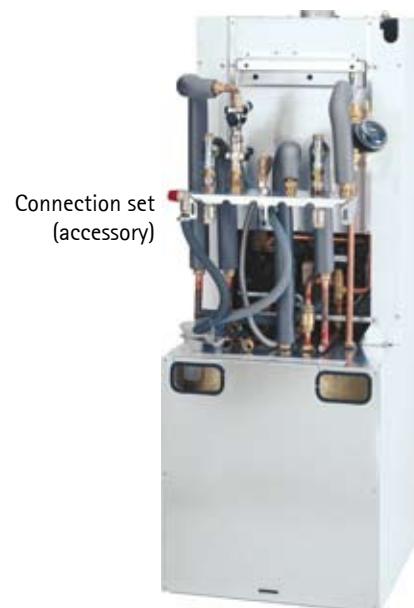
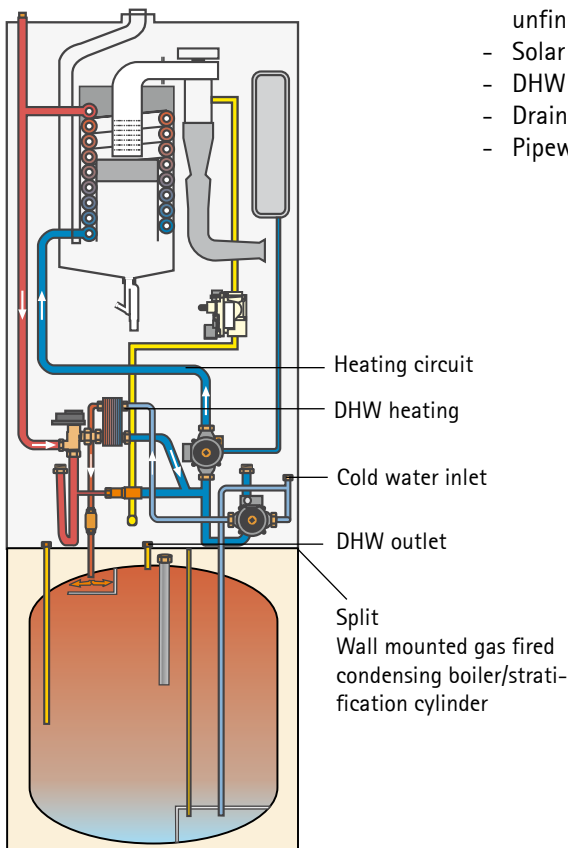

Gas fired condensing boilers ComfortLine

CGB-35, -50 wall mounted gas fired condensing central heating boilers

CGB-K40-35 wall mounted gas fired condensing boilers for DHW and central heating



Figure: CGB-35,-50

Wall mounted gas fired condensing central heating boiler CGB-35, -50, sealed combustion chamber, for open and balanced flue operation, may be combined with DHW cylinders, e.g. SE-2

Wall mounted gas fired condensing boiler CGB-K40-35 for DHW and central heating with integral stainless steel DHW heat exchanger, sealed combustion chamber, for open and balanced flue operation



- Modulation range for flow/return 50/30 °C:
CGB-35, CGB-K40-35 from 9.0 to 35.0 kW
CGB-50 from 12.2 to 50.0 kW
- Booster output for DHW heating:
CGB-K40-35 40.0 kW
- Certified with the DVGW quality symbol; tested in accordance with German and European Directives; extremely clean combustion
- High standard efficiency up to 110% (Hi) / 99% (Hs) for the best possible energy utilisation
- The CGB-35, CGB-K40-35 meets the requirements for the „Blue Angel“ certificate of environmental excellence to RAL-UZ 61 when operated with natural gas
- Premix burner for natural gas E, LL and LPG
- As standard with modulating heating circuit pump or modulating high efficiency pump class A; no mechanical switches in the heating water
- Easy installation, operation and maintenance through convenient access to all components
- Flue gas test port accessible from outside; the equipment does not need to be opened
- 2 year warranty
- Heating water heat exchanger can be pivoted into two maintenance positions for easy cleaning without having to drain off the heating water

Easy maintenance

For maintenance and cleaning, the heat exchanger can be pivoted into two different maintenance positions.



Wartungsposition 1:
Demontage der Brenneinheit



Wartungsposition 2:
Reinigung des Wärmetauschers mit Reinigungsbeutel und Bürste (Zubehör)

Gas fired condensing boilers ComfortLine

CGB-75, -100 wall mounted gas fired condensing central heating boilers



Wall mounted gas fired condensing central heating boilers CGB-75, -100, sealed combustion chamber, for open and balanced flue operation, may be combined with DHW cylinders, e.g. SE-2

- Modulation range for flow/return 50/30 °C:

CGB-75	from 19.6 to 75.8 kW
CGB-100	from 19.6 to 98.8 kW
- Tested in accordance with German and European Directives; extremely clean combustion
- High standard efficiency up to 110% (Hi) / 99% (Hs) for the best possible energy utilisation
- The conditions set for the „Blue Angel“ certificate of environmental excellence acc. to RAL UZ 61 are met
- Premix burner for natural gas E, LL and LPG
- Easy installation, operation and maintenance through convenient access to all components
- Standard flue gas non-return device; lowest cool-down losses; optional cascade operation with positive pressure for up to four wall mounted gas fired condensing boilers and an output range up to 400 kW
- High performance heat exchanger made from a robust aluminium:silicone alloy, with vertically arranged smooth fins; easy cleaning, high self-cleaning effect; long service life
- Compact space-saving design; side clearances for installation and maintenance are not required
- Flue gas test port accessible from outside; the equipment does not need to be opened
- The heating water heat exchanger can be cleaned under system pressure, i.e. without need to drain off the heating water
- No minimum throughput and overflow valve required
- 2 year warranty



Easy maintenance



After the burner unit has been removed, the smooth heat exchanger fins can be easily cleaned.

Hydraulic connections

CGB connections

- 1 Heating flow
- 2 Heating return
- 3 Gas connection
- 4 Condensate drain
- 5 DHW flow
- 6 Cylinder return

CGB-11, 20, 24

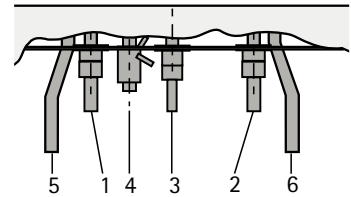
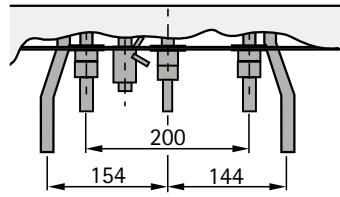

CGB-35, 50

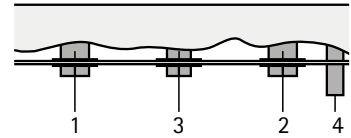
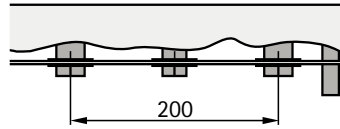

CGB-75, 100

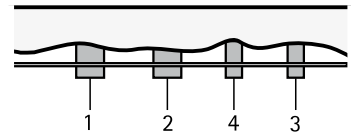
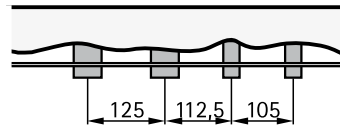

CGB-K connections

- 1 Heating flow
- 2 Heating return
- 3 Gas connection
- 4 Condensate drain
- 5 DHW connection (on site)
- 6 DHW connection
- 7 Cold water connection
- 8 Cold water connection (on site)

CGB-K-20, 24

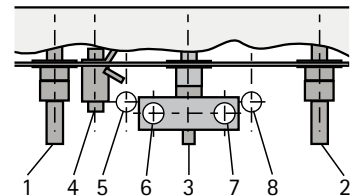
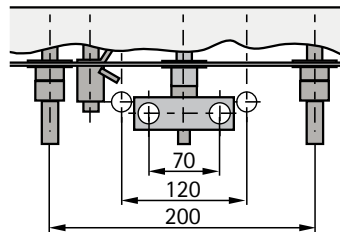

CGB-K40-35

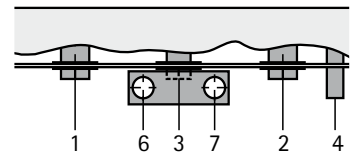
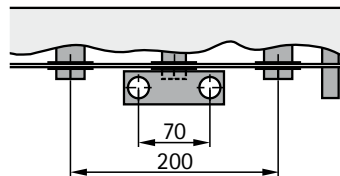

CGW connections

- 1 Heating flow
- 2 Heating return
- 3 Gas connection
- 4 DHW connection
- 5 Cold water connection
- 6 DHW circulation line

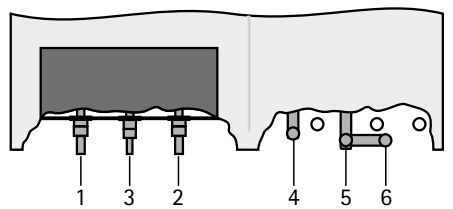
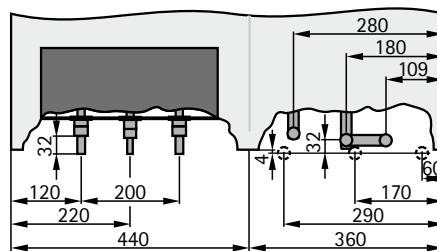

CGS connections

- 1 Heating flow
- 2 Heating return
- 3 Gas connection
- 4 DHW connection
- 5 Cold water connection
- 6 BDF valve
- 7 DHW circulation line

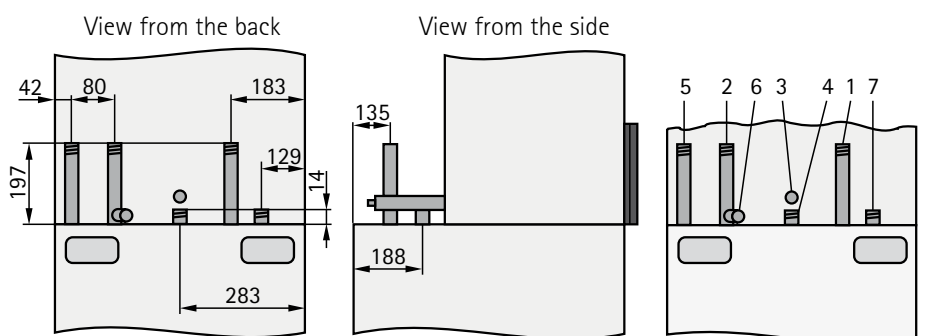

Gas fired condensing solar centres CSZ ComfortLine

The [German] „Renewable Energies Heat Act“ (short EEWärmeG) obliges owners of new buildings to cover a percentage of the heat demand with renewable energy.

In accordance with the obligation under the Renewable Energies Heat Act (EEWärmeG) to use renewables, 15% of the heat demand must be provided by solar energy. For residential buildings with a maximum of two apartments, a collector surface area of at least 0.04 m² per m² floor area is to be calculated.

With its CSZ product range, Wolf offers the optimum, compact solution – gas condensing technology combined with solar DHW heating – with a solar coverage rate of up to 60% for buildings with up to 150 m² floor area.

CSZ-11/300, -20/300, 24/300 gas fired condensing solar centres ComfortLine

Gas condensing solar centre ComfortLine CSZ in modular form

Output from 3.6 to 20.5 kW, for central and DHW heating, comprising:

- Gas condensing boiler, solar cylinder, solar pump assembly with solar module SM1 and 25 l expansion vessel, 10 l collecting vessel for heat transfer medium standard control unit for gas condensing boiler with programming module BM incl. outside temperature sensor
- Compact design – the gas condensing solar centre fits in almost any recess
- Side clearances for service purposes are not required as all components are accessible from the front; minimal clearance required on the connection side
- Can be installed directly in front of a wall
- Connections for central heating and solar circuit either on the l.h. or r.h. side
- Connections for DHW, cold water and DHW circulation at the top
- As standard, equipped with a high efficiency solar circuit pump eligible for subsidy



- **Wall mounted gas condensing boiler** for open or open balanced flue operation; certified with the DVGW quality symbol; tested in accordance with German and European Directives; extremely clean combustion
 - High seasonal efficiency [to DIN] up to 110% (Hi) / 99% (Hs) for the best possible energy utilisation
 - Meets the requirements for the „Blue Angel“ certificate of environmental excellence to RAL-UZ 61 when operated with natural gas, as well as the limit values of the „Hannover Pro Climate Subsidy Programme“
 - Premix burner for natural gas E, LL and LPG (LPG for CSZ-20/300 only)
 - As standard with expansion vessel and modulating high efficiency pump class A
 - Coated heating water heat exchanger can be pivoted for easy cleaning without having to drain off the heating water
 - Easy installation, operation and maintenance through convenient access to all components
 - Flue gas test port accessible from outside; the equipment does not need to be opened
-
- Modulation range for flow/return 50/30°C:
 - CSZ-11/300 from 3.6 to 10.9 kW
 - CSZ-20/300 from 6.1 to 20.5 kW
 - CSZ-24/300 from 7.8 to 24.8 kW
 - Booster output during cylinder heating:
 - CSZ-11/300 14.6 kW
 - CSZ-20/300 22.9 kW
 - CSZ-20/300 27.6 kW

Gas fired condensing solar centres CSZ ComfortLine



- **Solar cylinder**, 310 l capacity, made of steel with two robust, bare tube internal indirect coils for very hard water, with enamel coating to DIN 4753
- Highly-effective thermal insulation and low thermal losses through high-grade HDPU foam insulation below the cylinder foil casing
- Thermal insulation is CFC and FC free
- The interior of the cylinder and the indirect coils are protected by an enamel coating and a protective magnesium anode
- Large indirect coil areas ensure a short heat-up time and a high constant DHW output
- Control unit with solar-dependent boiler cut-off for high solar yield
- With its compact design and single casing, which has a space requirement of 600 x 1013 mm, the gas condensing solar centre will fit in almost any recess.
- Minimum clearance required on the connection side
- All control and service elements are accessible from the front. This enables a variety of installation options
- 2 year warranty for boiler
- 5 year warranty for DHW-cylinder

Hydraulic connections

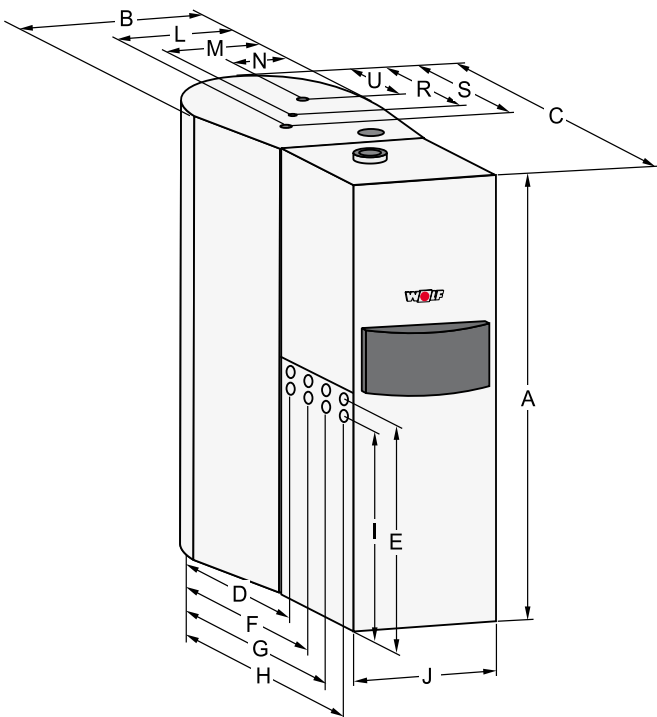

Type	CSZ-	11/300, 20/300, 24/300
Height *	A mm	1850
Total width	B mm	600
Total length	C mm	1013
Left hand connection side		
Heating flow	D/E mm	668 / 954
Heating return	F/E mm	748 / 954
Solar circuit flow	G/E mm	828 / 954
Solar circuit return	H/E mm	908 / 954
Gas connection	H/I mm	908 / 889
Right hand connection side		
Heating flow	F/E mm	748 / 954
Heating return	D/E mm	668 / 954
Solar circuit flow	H/E mm	908 / 954
Solar circuit return	G/E mm	828 / 954
Gas connection	H/I mm	908 / 889
Width of gas fired condensing boiler	J mm	440
Circulation	S/L mm	370 / 370
DHW	R/M mm	300 / 300
Cold water	U/N mm	230 / 230

* Min. ceiling height 2.1 m

Specification CGB

Type		CGB-11	CGB-20	CGB-24	CGB-35	CGB-50	CGB-75	CGB-100
Rated output at 80/60°C	kW	10.0/14.6 ¹⁾	19.0/22.9 ¹⁾	23.1/27.6 ¹⁾	32	46	70.1	91.9
Rated output at 50/30°C	kW	10.9	20.5	24.8	34.9	49.9	75.8	98.8
Rated thermal load	kW	10.3/15.0 ¹⁾	19.5/23.5 ¹⁾	23.8/28.5 ¹⁾	33	47	71.5	94
Boiler output (modul.) at 80/60°C	kW	3.2	5.6	7.1	8/8.5 ³⁾	11/11.7 ³⁾	18.2	18.2
Boiler output (modul.) at 50/30°C	kW	3.6	6.1	7.8	9/9.5 ³⁾	12.2/12.9 ³⁾	19.6	19.6
Boiler thermal load (modul.)	kW	3.3	5.7	7.3	8.5/9 ³⁾	11.7/12.4 ³⁾	18.5	18.5
Heating flow outside diameter	G	3/4"	3/4"	3/4"	1 1/4"	1 1/4"	1 1/2"	1 1/2"
Heating return outside diameter	G	3/4"	3/4"	3/4"	1 1/4"	1 1/4"	1 1/2"	1 1/2"
DHW connection/DHW circulation	G	3/4"	3/4"	3/4"	-	-	-	-
Cold water connection	G	3/4"	3/4"	3/4"	-	-	-	-
Gas connection	R	1/2"	1/2"	1/2"	3/4"	3/4"	3/4"	3/4"
Air/flue gas connection	mm	60/100	60/100	60/100	80/125	80/125	110/160	110/160
Gas category		I ₂ ELL	II ₂ ELL3B/P	II ₂ ELL3P	II ₂ ELL3P	II ₂ ELL3P	II ₂ ELL3P	II ₂ ELL3P
Gas supply details:								
Nat. gas E/H (H _i = 9.5 kWh/m ³ = 34.2 MJ/m ³)	m ³ /h	1.08/1.58 ¹⁾	2.05/2.47 ¹⁾	2.50/3.00 ¹⁾	3.47	4.94	7.77	10.03
Nat. gas LL (H _i = 8.6 kWh/m ³ = 31.0 MJ/m ³) ²⁾	m ³ /h	1.20/1.74 ¹⁾	2.27/2.73 ¹⁾	2.77/3.31 ¹⁾	3.84	5.5	8.6	11.11
LPG (H _i = 12.8 kWh/kg = 46.1 MJ/kg)	kg/h	-	1.52/1.84 ¹⁾	1.86/2.23 ¹⁾	2.57	3.66	5.76	7.44
Gas supply pressure: Natural gas	mbar	20	20	20	20	20	20	20
LPG	mbar	-	50	50	50	50	50	50
Standard efficiency at 40/30°C (Hi/Hs)	%	110/99	109/98	109/98	109/98	110/99	110/99	110/99
Standard efficiency at 75/60°C (Hi/Hs)	%	107/96	107/96	106/96	108/97	107/96	107/96	107/96
Efficiency at rated load at 80/60 °C (Hi/Hs)	%	98/88	98/88	98/88	98/88	98/88	98/88	97/88
Efficiency at 30% partial load and TR=30°C (Hi/Hs)	%	108/97	107/97	107/97	109/98	109/98	107/96	107/96
Factory-set flow temperature	°C	75	75	75	75	75	80	80
Flow temperature up to approx.	°C	90	90	90	90	90	90	90
Max. system pressure	bar	3.0	3.0	3.0	3.0	3.0	6.0	6.0
Residual head for heating circuit								
3-stage pump at stages 3/2/1								
570 l/h pump rate (10kW at Δt=15K)	mbar	250/250/100	250/250/100	250/250/100	-	-	-	-
860 l/h pump rate (15kW at Δt=15K)	mbar	-	250/160/-	250/160/-	-	-	-	-
1140 l/h pump rate (20kW at Δt=15K)	mbar	-	140/-/-	140/-/-	-	-	-	-
Regulated pump (100%)								
475 l/h pump rate (11kW at Δt=20K)	mbar	150	250	250	-	-	-	-
860 l/h pump rate (20kW at Δt=20K)	mbar	-	100	190	-	-	-	-
977 l/h pump rate (46kW at Δt=20K)	mbar	-	-	-	175	210	-	-
1834 l/h pump rate (32kW at Δt=20K)	mbar	-	-	-	-	195	-	-
3000 l/h pump rate (70kW at Δt=20K)	mbar	-	-	-	-	-	300	-
4000 l/h pump rate (92kW at Δt=20K)	mbar	-	-	-	-	-	-	80
Heating water heat exchanger water content	Ltr.	1.3	1.3	1.3	2.5	2.5	10	10
Expansion vessel: Total content	Ltr.	12	12	12	-	-	-	-
Inlet pressure	bar	0.75	0.75	0.75	-	-	-	-
Permissible sensor temperatures	°C	95	95	95	95	95	95	95
Flue gas mass flow at Q _{max}	g/s	4.7/6.8 ¹⁾	8.9/10.7 ¹⁾	10.8/13.0 ¹⁾	15	21.5	33.7	43.5
Flue gas mass flow at Q _{min}	g/s	1.45	2.62	2.7	3.9	5.3	8.9	8.9
Flue gas temperature 80/60-50/30 at Q _{max}	°C	75-45	75-45	85-45	65-45	80-50	72-48	78-53
Flue gas temperature 80/60-50/30 at Q _{min}	°C	45-26	36-27	43-41	66-47	60-38	60-36	60-36
Available gas fan draught at Q _{max}	Pa	90	90	90	115	145	145	200
Available gas fan draught at Q _{min}	Pa	12	12	12	10	10	12	12
Flue gas group according to DVGW G 635	G52	G52	G52	G52	G52	G52	G52	G52
NOx class	5	5	5	5	5	5	5	5
Electrical connection	V~/Hz	230/50	230/50	230/50	230/50	230/50	230/50	230/50
Fitted fuse (medium slow)	A	3.15	3.15	3.15	3.15	3.15	3.15	3.15
Power consumption with modulating pump class A pump	W	90	90	90	110	150	-	-
Power consumption with 3-stage-pump	W	110	110	110	130	175	75	130
Protection	IPX4D	IPX4D	IPX4D	IPX4D	IPX4D	IPX4D	IPX4D	IPX4D
Total weight (dry):	kg	42	42	42	45	45	92	92
Condensate volume at 50/30°C	Ltr./h	approx. 1.2	approx. 2.0	approx. 2.4	approx. 3.9	approx. 5.5	approx. 7.1	approx. 9.8
Condensate pH value		approx. 4.0	approx. 4.0	approx. 4.0	approx. 4.0	approx. 4.0	approx. 4.0	approx. 4.0
CE ID		CE-0085BN0380			CE-0085BP5571		CE-0085BR0164	
DIN DVGW quality symbol		QG-3202AV0430			QG-3202BQ0155		-	

¹⁾ Heating operation / DHW operation ²⁾ Not applicable to Austria / Switzerland ³⁾ LPG

CSW-120 DHW cylinder

Cylinder capacity	Ltr.	115
Constant DHW cylinder rating (80/60 - 10/45 °C)	kW-Ltr./h	29-710
Standby loss	kWh/24 h	1,5
Output factor	N _i	1,0
Max. operating pressure – DHW	bar	10
Max. operating pressure – heating water	bar	12
Max. permissible DHW cylinder temperature	°C	92
Max. permissible heating water temperature	°C	110
Weight (dry)	kg	65

Specification CGB-K

Type		CGB-K-20	CGB-K-24	CGB-K40-35
Rated output at 80/60°C	kW	19.0/22.9 ¹⁾	23.1/27.6 ¹⁾	32/39 ¹⁾
Rated output at 50/30°C	kW	20.5	24.8	34.9
Rated thermal load	kW	19.5/23.5 ¹⁾	23.8/28 ¹⁾	33/40 ¹⁾
Boiler output (modul.) at 80/60°C	kW	5.6	7.1	8/8.5 ³⁾
Boiler output (modul.) at 50/30°C	kW	6.1	7.8	9/9.5 ³⁾
Boiler thermal load (modul.)	kW	5.7	7.3	8.5/9 ³⁾
Heating flow outside diameter	G	3/4"	3/4"	1 1/4"
Heating return outside diameter	G	3/4"	3/4"	1 1/4"
DHW connection/DHW circulation	G	3/4"	3/4"	3/4"
Cold water connection	G	3/4"	3/4"	3/4"
Gas connection	R	1/2"	1/2"	3/4"
Air/flue gas connection	mm	60/100	60/100	80/125
Gas category		I ₂ ELL3B/P	II ₂ ELL3P	II ₂ ELL3P
Gas supply details:				
Nat. gas E/H (H _i = 9.5 kWh/m ³ = 34.2 MJ/m ³)	m ³ /h	2.05/2.47 ¹⁾	2.50/3.00 ¹⁾	3.47/4.34 ¹⁾
Nat. gas LL (H _i = 8.6 kWh/m ³ = 31.0 MJ/m ³) ²⁾	m ³ /h	2.27/2.73 ¹⁾	2.77/3.31 ¹⁾	3.84/5.10 ¹⁾
LPG (H _i = 12.8 kWh/kg = 46.1 MJ/kg)	kg/h	1.52/1.84 ¹⁾	1.86/2.23 ¹⁾	2.57/3.40 ¹⁾
Gas supply pressure: Natural gas	mbar	20	20	20
LPG	mbar	50	50	50
Standard efficiency at 40/30°C (Hi/Hs)	%	110/99	109/98	109/98
Standard efficiency at 75/60°C (Hi/Hs)	%	107/96	107/96	106/96
Efficiency at rated load at 80/60 °C (Hi/Hs)	%	98/88	98/88	98/88
Efficiency at 30% partial load and TR=30°C (Hi/Hs)	%	108/97	107/97	107/97
Factory-set flow temperature	°C	75	75	75
Flow temperature up to approx.	°C	90	90	90
Max. system pressure	bar	3.0	3.0	3.0
Residual head for heating circuit				
3-stage pump at stages 3/2/1				
570 l/h pump rate (10kW at Δt=15K)	mbar	250/250/100	250/250/100	-
860 l/h pump rate (15kW at Δt=15K)	mbar	250/100/-	250/100/-	-
1140 l/h pump rate (20kW at Δt=15K)	mbar	140/-/-	140/-/-	-
Regulated pump (100%)				
475 l/h pump rate (11kW at Δt=20K)	mbar	250	250	-
860 l/h pump rate (20kW at Δt=20K)	mbar	110	190	-
1834 l/h pump rate (32kW at Δt=20K)	mbar	-	-	175
Heating water heat exchanger water content	Ltr.	1.3	1.3	2.5
DHW throughput	l/min	2.0-6.5	2.0-8.0	2.0-12.0
Spec. water throughput „D“ to DIN EN 625	l/min	9.4	13	18
Min. flow pressure/min. flow pressure to EN 625	bar	0.2/1.0	0.2/1.0	0.2/1.0
Max. design pressure	bar	10	10	10
DHW temperature range (adjustable) ⁴⁾	°C	40-60	40-60	15-65
DHW heat exchanger corrosion protection		Stainless steel	Stainless steel	Stainless steel
Expansion vessel: Total content	Ltr.	12	12	-
Inlet pressure	bar	0.75	0.75	-
Permissible sensor temperatures	°C	95	95	95
Flue gas mass flow at Q _{max}	g/s	8.9/10.7 ¹⁾	10.8/13.0 ¹⁾	15/18 ¹⁾
Flue gas mass flow at Q _{min}	g/s	2.62	2.7	3.9
Flue gas temperature 80/60-50/30 at Q _{max}	°C	75-45	85-45	65-45
Flue gas temperature 80/60-50/30 at Q _{min}	°C	36-27	43-41	66-47
Available gas fan draught at Q _{max}	Pa	90	90	115/125 ¹⁾
Available gas fan draught at Q _{min}	Pa	12	12	10
Flue gas group according to DVGW G 635		G52	G52	G52
NOx class		5	5	5
Electrical connection	V~/Hz	230/50	230/50	230/50
Fitted fuse (medium slow)	A	3.15	3.15	3.15
Power consumption with modulating pump class A pump	W	90	105	115
Power consumption with 3-stage-pump	W	110	110	135
Protection		IPX4D	IPX4D	IPX4D
Total weight (dry):	kg	45	45	48
Condensate volume at 50/30°C	Ltr./h	approx. 2.0	approx. 2.4	3.9/4.4 ¹⁾
Condensate pH value		approx. 4.0	approx. 4.0	approx. 4.0
CE ID		CE-0085BN0380	CE-0085BN0380	CE-0085BP5571
DIN DVGW quality symbol		QG-3202AV0430	QG-3202AV0430	QG-3202BQ0155

¹⁾ Heating operation / DHW operation ²⁾ Not applicable to Austria / Switzerland ³⁾ LPG ⁴⁾ Relative to a cold water temperature of 10 °C

Specification CGW / CGS

Type		CGW-11/100	CGW-20/120	CGW-24/140	CGS-20/160	CGS-24/200
Rated output at 80/60°C	kW	10.0/14.6	19.0/22.9 ¹⁾	23.1/27.6 ¹⁾	19.0/22.9 ¹⁾	23.1/27.6 ¹⁾
Rated output at 50/30°C	kW	10.9	20.5	24.8	20.5	24.8
Rated thermal load	kW	10.3/15.0	19.5/23.5 ¹⁾	23.8/28.5 ¹⁾	19.5/23.5 ¹⁾	23.8/28.5 ¹⁾
Boiler output (modul.) at 80/60°C	kW	3.2	5.6	7.1	5.6	7.1
Boiler output (modul.) at 50/30°C	kW	3.6	6.1	7.8	6.1	7.8
Boiler thermal load (modul.)	kW	3.3	5.7	7.3	5.7	7.3
Heating flow outside diameter	G	3/4"	3/4"	3/4"	3/4"	3/4"
Heating return outside diameter	G	3/4"	3/4"	3/4"	3/4"	3/4"
DHW connection/DHW circulation	G	3/4"	3/4"	3/4"	3/4"	3/4"
Cold water connection	G	3/4"	3/4"	3/4"	3/4"	3/4"
Gas connection	R	1/2"	1/2"	1/2"	1/2"	1/2"
Air/flue gas connection	mm	60/100	60/100	60/100	60/100	60/100
Gas category		I ₂ ELL	II ₂ ELL3B/P	II ₂ ELL3P	II ₂ ELL3B/P	II ₂ ELL3P
Gas supply details:						
Nat. gas E/H (H _i = 9.5 kWh/m ³ = 34.2 MJ/m ³)	m ³ /h	1.08/1.58 ¹⁾	2.05/2.47 ¹⁾	2.50/3.00 ¹⁾	2.05/2.47 ¹⁾	2.50/3.00 ¹⁾
Nat. gas LL (H _i = 8.6 kWh/m ³ = 31.0 MJ/m ³) ²⁾	m ³ /h	1.20/1.74 ¹⁾	2.27/2.73 ¹⁾	2.77/3.31 ¹⁾	2.27/2.73 ¹⁾	2.77/3.31 ¹⁾
LPG (H _i = 12.8 kWh/kg = 46.1 MJ/kg)	kg/h	-	1.52/1.84 ¹⁾	1.86/2.23 ¹⁾	1.52/1.84 ¹⁾	1.86/2.23 ¹⁾
Gas supply pressure: Natural gas	mbar	20	20	20	20	20
LPG	mbar	-	50	50	50	50
Standard efficiency at 40/30°C (Hi/Hs)	%	110/99	109/98	110/99	110/99	110/99
Standard efficiency at 75/60°C (Hi/Hs)	%	107/96	108/97	107/96	107/96	107/96
Efficiency at rated load at 80/60 °C (Hi/Hs)	%	98/88	98/88	98/88	98/88	97/88
Efficiency at 30% partial load and TR=30°C (Hi/Hs)	%	108/97	109/98	109/98	107/96	107/96
Factory-set flow temperature	°C	75	75	75	75	75
Flow temperature up to approx.	°C	90	90	90	90	90
Max. system pressure	bar	3.0	3.0	3.0	3.0	3.0
Residual head for heating circuit:						
3-stage pump at stage 3/2/1						
570 l/h pump rate (10kW at Δt=15K)	mbar	-	250/250/100	250/250/100	250/250/100	250/250/100
860 l/h pump rate (15kW at Δt=15K)	mbar	-	250/160/-	250/160/-	250/160/-	250/160/-
1140 l/h pump rate (20kW at Δt=15K)	mbar	-	140/-/-	140/-/-	140/-/-	140/-/-
Regulated pump (100%)						
475 l/h pump rate (11kW at Δt=20K)	mbar	240	250	250	250	250
860 l/h pump rate (20kW at Δt=20K)	mbar	-	110	190	110	190
Heating water heat exchanger water content	Ltr.	1.3	1.3	1.3	1.3	1.3
Nominal content / equivalent rated content of the stratification cylinder	Ltr.	50/100	50/120	50/140	90/160	90/160
Spec. water throughput „D“ to DIN EN 625	l/min	14.7	17.9	20	23.2	25.2
Continuous DHW rating	l/h (kW)	360 (14.6)	563 (22.9)	681 (27.6)	563 (22.9)	681 (27.6)
Performance factors to DIN 4708	N _i	0.8	1.1	1.5	2.1	2.5
DHW output	l/10 min	115	150	171	199	216
Standby loss	kWh/24h	0.8	0.8	0.8	1.1	1.1
Max. design pressure	bar	10	10	10	10	10
DHW temperature range (adjustable) ⁴⁾	°C	15-65	15-65	15-65	15-65	15-65
DHW heat exchanger corrosion protection		Stainless steel	Stainless steel	Stainless steel	Stainless steel	Stainless steel
Cylinder corrosion protection		Stainless steel	Stainless steel	Stainless steel	Enamelled to DIN 4753	Enamelled to DIN 4753
Expansion vessel: Total content	Ltr.	12	12	12	12	12
Inlet pressure	bar	0.75	0.75	0.75	0.75	0.75
Permissible sensor temperatures	°C	95	95	95	95	95
Flue gas mass flow at Q _{max}	g/s	4.7/6.8 ¹⁾	8.9/10.7 ¹⁾	10.8/13.0 ¹⁾	8.9/10.7 ¹⁾	10.8/13.0 ¹⁾
Flue gas mass flow at Q _{min}	g/s	1.45	2.62	2.7	2.62	2.7
Flue gas temperature 80/60-50/30 at Q _{max}	°C	75-45	75-45	85-45	75-45	85-45
Flue gas temperature 80/60-50/30 at Q _{min}	°C	45-26	36-27	43-41	36-27	43-41
Available gas fan draught at Q _{max}	Pa	90	90	90	90	90
Available gas fan draught at Q _{min}	Pa	12	12	12	12	12
Flue gas group according to DVGW G 635		G52	G52	G52	G52	G52
NO _x class		5	5	5	5	5
Electrical connection	V~/Hz	230/50	230/50	230/50	230/50	230/50
Fitted fuse (medium slow)	A	3.15	3.15	3.15	3.15	3.15
Power consumption with modulating pump class A pump	W	125	125	140	125	140
Power consumption with 3-stage-pump	W	-	145	145	145	145
Protection		IPX4D	IPX4D	IPX4D	IPX4D	IPX4D
Total weight (dry):	kg	70	70	70	99	99
Condensate volume at 50/30°C	Ltr./h	approx. 1.2	approx. 2.0	approx. 2.4	approx. 2.0	approx. 2.4
Condensate pH value		approx. 4.0	approx. 4.0	approx. 4.0	approx. 4.0	approx. 4.0
CE ID		CE-0085B00001				
DIN DVGW quality symbol		QG-3204B00014				

¹⁾ Heating operation / DHW operation ²⁾ Not applicable to Austria / Switzerland ³⁾ LPG ⁴⁾ Relative to a cold water temperature of 10 °C

Specification CSZ

Type		CSZ-11/300	CSZ-20/300	CSZ-24/300
Rated output at 80/60°C	kW	10.0/14.6 ¹⁾	19.0/22.9 ¹⁾	23.1/27.6 ¹⁾
Rated output at 50/30°C	kW	10.9	20.5	24.8
Rated thermal load	kW	10.3/15.0 ¹⁾	19.5/25.5 ¹⁾	23.8/28.5 ¹⁾
Boiler output (modul.) at 80/60°C	kW	3.2	5.6	7.1
Boiler output (modul.) at 50/30°C	kW	3.6	6.1	7.8
Boiler thermal load (modul.)	kW	3.3	5.7	7.3
Heating flow outside diameter	G	3/4"	3/4"	3/4"
Heating return outside diameter	G	3/4"	3/4"	3/4"
DHW connection/DHW circulation	G	3/4"	3/4"	3/4"
Cold water connection	G	3/4"	3/4"	3/4"
Gas connection	R	1/2"	1/2"	1/2"
Air/flue gas connection	mm	60/100	60/100	60/100
Gas category		I ₂ ELL	II ₂ ELL3B/P	II ₂ ELL3P
Gas supply details:				
Nat. gas E/H (H _i = 9.5 kWh/m ³ = 34.2 MJ/m ³)	m ³ /h	1.08/1.58 ¹⁾	2.05/2.47 ¹⁾	2.50/3.00 ¹⁾
Nat. gas LL (H _i = 8.6 kWh/m ³ = 31.0 MJ/m ³) ²⁾	m ³ /h	1.20/1.74 ¹⁾	2.27/2.73 ¹⁾	2.77/3.31 ¹⁾
LPG (H _i = 12.8 kWh/kg = 46.1 MJ/kg)	kg/h	-	1.52/1.84 ¹⁾	1.86/2.23 ¹⁾
Gas supply pressure: Natural gas	mbar	20	20	20
LPG	mbar	-	50	50
Standard efficiency at 40/30°C (Hi/Hs)	%	110/99	109/98	109/98
Standard efficiency at 75/60°C (Hi/Hs)	%	107/96	107/96	106/96
Efficiency at rated load at 80/60 °C (Hi/Hs)	%	98/88	98/88	98/88
Efficiency at 30% partial load and TR=30°C (Hi/Hs)	%	108/97	107/97	107/97
Factory-set flow temperature	°C	75	75	75
Flow temperature up to approx.	°C	90	90	90
Max. system pressure	bar	3.0	3.0	3.0
Residual head for heating circuit:				
475 l/h pump rate (11kW at Δt=20K)	mbar	200	220	220
860 l/h pump rate (20kW at Δt=20K)	mbar	-	175	185
Heating water heat exchanger water content	Ltr.	1.3	1.3	1.3
Cylinder capacity	Ltr.	310	310	310
Constant DHW cylinder output 75/60-10/45 °C (heating) l/h (kW)		360 (14.6)	564 (22.9)	680 (27.6)
Performance factor	N ₆₀	1.5	2.3	2.3
Primary-heating water	bar / °C	10 / 110	10 / 110	10 / 110
Secondary-DHW	bar / °C	10 / 95	10 / 95	10 / 95
Heat exchanger area (heating)	m ²	1.05	1.05	1.05
Heat exchanger area (solar)	m ²	1.37	1.37	1.37
Heat exchanger content (heating)	Ltr.	7.4	7.4	7.4
Heat exchanger content (solar)	Ltr.	10.2	10.2	10.2
Collecting vessel (solar fluid)	Ltr.	10	10	10
Expansion vessel: Total content	Ltr.	12 / 25	12 / 25	12 / 25
Inlet pressure	bar	0.75 / 2.5	0.75 / 2.5	0.75 / 2.5
Permissible sensor temperatures	°C	95	95	95
Flue gas mass flow at Q _{max}	g/s	4.7/6.8 ¹⁾	8.9/10.7 ¹⁾	10.8/13.0 ¹⁾
Flue gas mass flow at Q _{min}	g/s	1.45	2.62	2.7
Flue gas temperature 80/60-50/30 at Q _{max}	°C	75-45	75-45	85-45
Flue gas temperature 80/60-50/30 at Q _{min}	°C	45-26	36-27	43-41
Available gas fan draught at Q _{max}	Pa	90	90	90
Available gas fan draught at Q _{min}	Pa	12	12	12
Flue gas group according to DVGW G 635		G52	G52	G52
NO _x class		5	5	5
Electrical connection	V~/Hz	230/50	230/50	230/50
Fitted fuse (medium slow)	A	3.15	3.15	3.15
Power consumption	W	110	110	110
Protection		IP30	IP30	IP30
Transportgewicht Gasbrennwerttherme	kg	42	42	42
Transportgewicht Solarspeicher (leer)	kg	125	125	125
Aufstellgewicht CSZ komplett mit Wasser gefüllt	kg	590	590	590
Condensate volume at 50/30°C	Ltr./h	approx. 1.2	approx. 2.0	approx. 2.4
Condensate pH value		approx. 4.0	approx. 4.0	approx. 4.0
CE ID			CE-0085BN0380	
DIN DVGW quality symbol			QG-3202AV0430	

¹⁾ Heating operation / DHW operation ²⁾ Not applicable to Austria / Switzerland

Standard control CGB / CGB-K / CGW / CGS

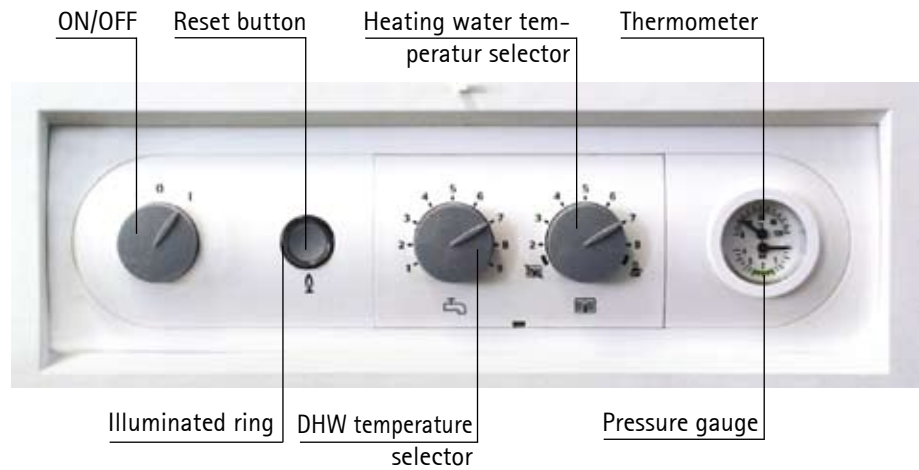
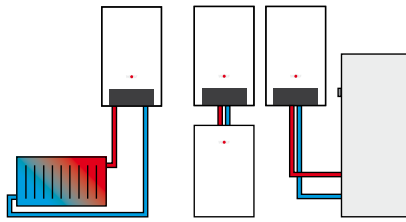

Illuminated indicator ring as status display

Display	Explanation
Flashing green	Standby (power supply ON, burner OFF)
Constant green	Heat demand: pump running, burner OFF
Flashing yellow	Emissions test mode
Constant yellow	Burner ON, flame steady
Flashing red	Fault

Settings

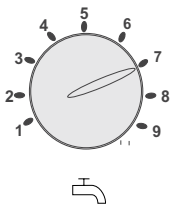

DHW temperature selector

The setting range 1-9 corresponds to a cylinder temperature of 15 to 65 °C. Combined with a control thermostat for wall mounted gas fired boilers, the adjustment at the DHW temperature selector is disabled; instead the temperature is selected at the boiler control thermostat.

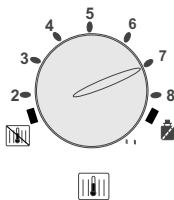

Heating water temperature selector

The setting range 2 - 8 corresponds to a heating water temperature of 20 to 75 °C. Combined with a control thermostat for wall mounted gas fired boilers, the adjustment at the heating water temperature selector is disabled; instead the temperature is selected at the boiler control thermostat.



Winter mode (position 2 to 8)

The circulation pump operates in heating mode.



Sommer mode

Switch set to  circulation pump OFF (heating OFF); only DHW heating, frost protection, pump anti-seizing protection enabled, i.e. the circulation pump runs for approx. 30 s every 24 hours.



Emissions test mode

Turning the switch to position  lets the boiler operate at maximum output. The illuminated indicator ring flashes yellow for 15 minutes or until the maximum flow temperature has been exceeded.



Thermometer/pressure gauge

The heating water temperature is displayed in the upper half, the heating system water pressure in the lower half.

Control accessories CGB / CGB-K / CGW / CGS

Two-wire eBUS cable



Standard controller; part of the standard delivery of the gas fired condensing boiler



BM programming module (incl. outside temperature sensor) as weather-compensated control thermostat

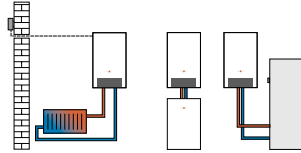

BM programming module with wall mounting base (accessory) as remote control

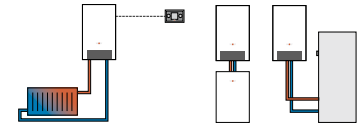

- room-/weather-compensated temperature control
- Time programs for DHW and central heating
- LCD with background illumination
- Easy plain text guide through the menus
- Control by rotary selector with key function
- Four function keys for frequently used functions (heating, DHW, setback, help)
- Installation either inside the boiler control unit or, as remote control, in a wall mounting base
- Option for mixer module MM
- Only one programming unit is required for multi-boiler systems
- May be extended with mixer module MM (up to 7 mixer circuits)
- Fault diagnosis

MM mixer module

- Extension module for regulating one mixer circuit
- Weather-compensated flow temperature control
- Easy controller configuration by selecting one of the preset system versions
- BM programming module to clip into boiler, or extendable with wall mounting base as remote control
- Rast-5 connection technology
- Incl. flow temperature sensor

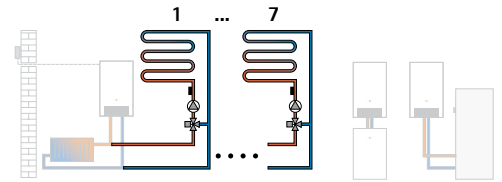

Solar module SM1

- Extension module for the regulation of one solar circuit
- In conjunction with Wolf boilers, greater energy savings through intelligent cylinder reheating, i.e. blocking cylinder reheating when there is sufficient solar yield
- Temperature differential controller for one heat consumer
- Maximum cylinder temperature limit
- Display of the set and actual values on the BM programming module
- Integral hours run meter
- Optional connection of heat meters
- Rast-5 connection technology
- Incl. collector sensor and cylinder sensor, each with sensor well

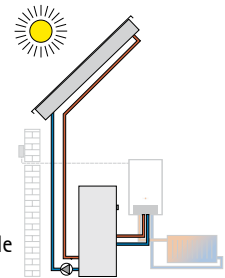

Solar module SM2

- Extension module for the regulation of a solar system including up to 2 cylinders and 2 collector fields, incl. 1 collector sensor, 1 cylinder sensor, each with sensor well
- Easy configuration of the controller through selection of pre-defined system options
- In conjunction with Wolf boilers, greater energy savings through intelligent cylinder reheating, i.e. blocking cylinder reheating when there is sufficient solar yield
- Heat meter function
- Display of the set and actual values on the BM programming module
- eBus interface with automatic energy management
- Rast-5 connection technology

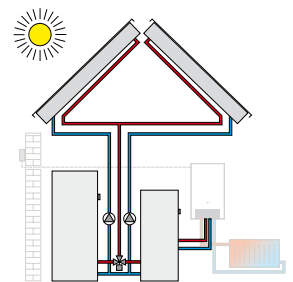

Control accessories CGB / CGB-K / CGW / CGS

Two-wire eBUS cable



Cascade module KM

- Extension module for control of systems with low loss header or cascade configuration
- Applicable for controls of condensing gas boilers (4 appliances)
- Easy configuration of the controller through selection of pre-defined system options
- Suitable for regulating one mixer circuit
- Programming module BM may either be plugged in or used as remote control with wall mounting base
- 0-10V input for building control network systems, fault signal output 230V
- eBus interface with automatic energy management
- Rast-5 connection technology

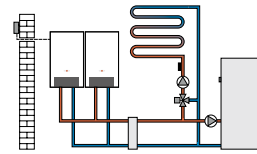

Radio clock (DCF 77 signal) with outside temperature sensor
for automatic time adjustment.



Radio clock (DCF 77 signal)
for automatic time adjustment.



External wireless sensor

(only in conjunction with a receiver for external wireless sensor and remote control, part no. 27 44 209)



Wireless receiver for wireless outside temperature sensor and wireless remote control

Incl. radio clock (DCF 77 signal)



Wireless remote control

(only in conjunction with a receiver for external wireless sensor and remote control)
Max. one wireless remote control per mixer circuit.



ISM 4 - LON interface module

for communication between the control unit and the building management system applying the LON standard network variables



WRS-Remote service system

for direct or remote access to the control system via PC and for transferring fault text messages.
Consisting of: Interface module ISM1 and remote service software „WRS-Soft“

Standard control CSZ

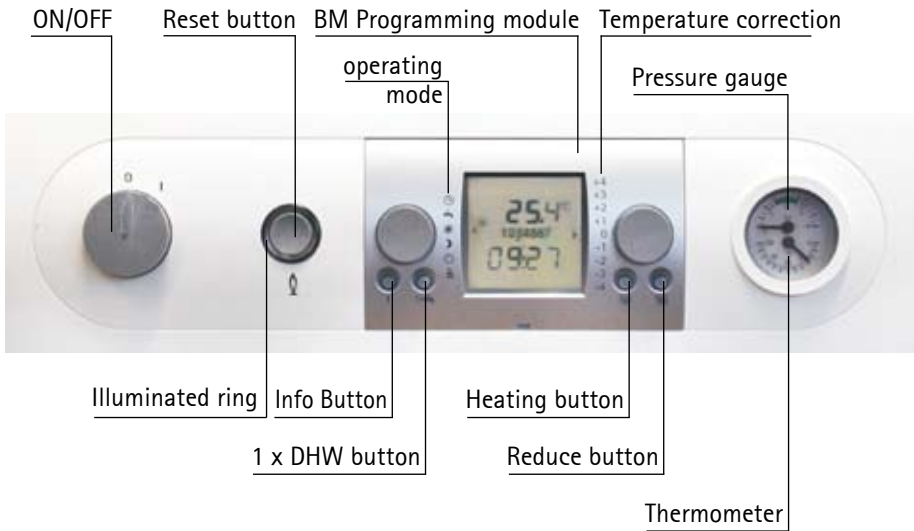
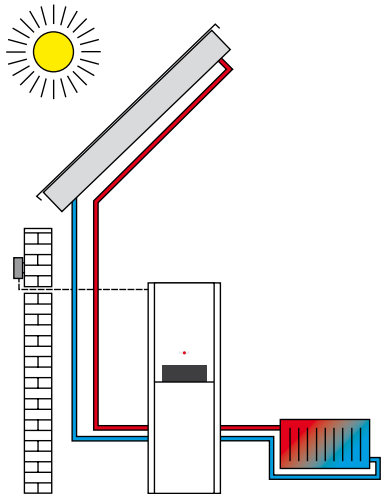

Weather-compensated temperature control incl. outside temperature sensor

- Time programs for DHW and central heating
- LCD with background illumination
- Easy plain text guide through the menus
- Control by rotary selector with key function
- Four function keys for frequently used functions (heating, DHW, setback, help)
- May be extended with mixer module MM (up to 7 mixer circuits)
- Fault diagnosis





Solar module SM1 for regulating one solar circuit (integrated into solar pump assembly)

- Solar circuit control for considerable energy savings through intelligent cylinder reheating, i.e. blocking cylinder reheating when there is sufficient solar yield (solar boiler stop)
- Temperature differential controller for one heat consumer
- Maximum cylinder temperature limit
- Display of the set and actual values on the BM programming module
- Integral hours run meter
- Optional connection of heat meters
- Rast-5 connection technology
- Incl. collector sensor and cylinder sensor, each with sensor well

Operating modes of the programming module BM

- 

Automatic timer mode
Heating at programmed times, Hot water generation at programmed times, Circulation pump at programmed times
- 

Sommer mode
Heating not in operation, Hot water generation at programmed times, Frost protection active, Pump standstill protection active
- 

Continuous mode
24 hour heating, 24 hour hot water generation, Circulation pump at programmed times
- 

Setback mode
Heating at reduced temperature, Hot water generation at programmed times, Circulation pump at programmed times
- 

Stand-by mode
Heating not in operation, Hot water generation not in operation, Frost protection active, Pump standstill protection active
- 

Flue gas test (BM programming module installed in boiler)
Full load operation for emissions measurement

Control accessories CSZ



Standard controller with programming module BM and Solar module SM1; part of the standard delivery of the gas fired condensing boiler

Two-wire eBUS cable



MM mixer module

- Extension module for regulating one mixer circuit
- Weather-compensated flow temperature control
- Easy controller configuration by selecting one of the preset system versions
- BM programming module to clip into boiler, or extendable with wall mounting base as remote control
- Rast-5 connection technology
- Incl. flow temperature sensor

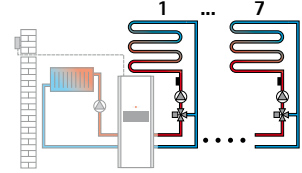

Radio clock (DCF 77 signal) with outside temperature sensor
for automatic time adjustment.



Radio clock (DCF 77 signal)
for automatic time adjustment.



External wireless sensor

(only in conjunction with a receiver for external wireless sensor and remote control, part no. 27 44 209)



Wireless receiver for wireless outside temperature sensor and wireless remote control

Incl. radio clock (DCF 77 signal)



Wireless remote control

(only in conjunction with a receiver for external wireless sensor and remote control)
Max. one wireless remote control per mixer circuit.



ISM 4 - LON interface module

for communication between the control unit and the building management system applying the LON standard network variables



WRS-Remote service system

for direct or remote access to the control system via PC and for transferring fault text messages.
Consisting of: Interface module ISM1 and remote service software „WRS-Soft“

Balanced flue routing for wall mounted gas fired boilers up to 24 kW gas fired condensing centres and gas fired condensing solar centres

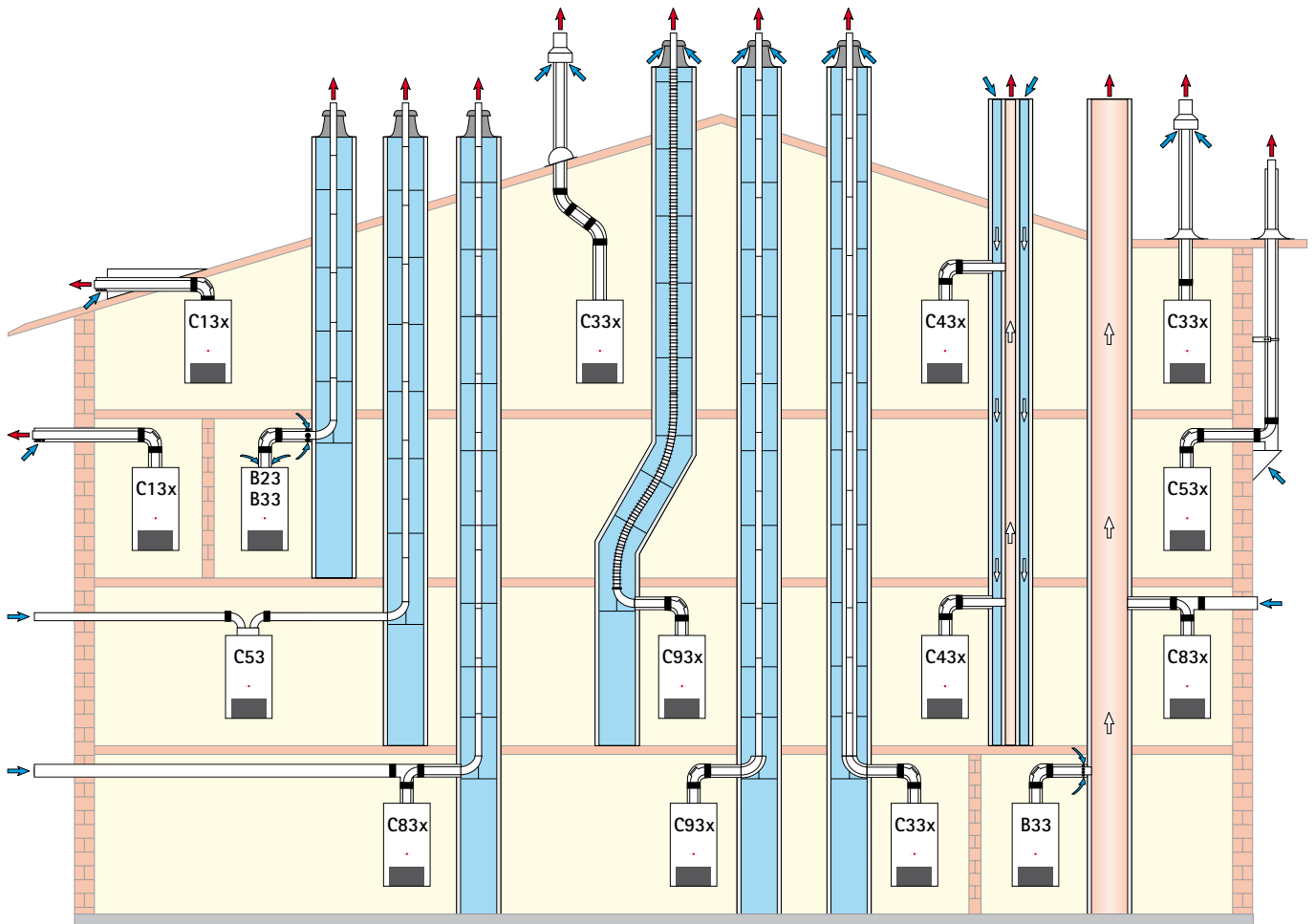

System versions		Maximum length ¹⁾ [m]	
		System DN60/100	System DN80/125
B23	Flue in a duct and combustion air directly through the boiler (open flue) + 2 m horizontal concentric connection line	-	30
B33	Flue in a duct with horizontal, concentric connection line (open flue)	13	30
B33	Connection to a moisture-resistant flue gas chimney with horizontal, concentric connection line (open flue)	Calculation to EN 13384 (LAS manufacturer)	
C13x	Horizontal roof outlet through a pitched roof except CGB-11 with DN 60/100 (balanced flue - on-site dormer)	9	10
C13x	Outside wall outlet (balanced flue) < 11 kW	5	10
C33x	Vertical concentric roof outlet through a pitched or flat roof, vertical concentric balanced flue routing for installation in a duct (balanced flue)	9	22
C43x	Connection to a moisture-resistant balanced flue chimney (LAS flue) maximum pipe length from the centre of the boiler bend to the connector 2 m (balanced flue)	Calculation to EN 13384 (LAS manufacturer)	
C53	Connection to the flue in a duct and ventilation air supply through the external wall	-	30
C53x	Connection to a flue on an external wall (balanced flue)	-	22
C83x	Connection to the flue in a duct and ventilation air through an external wall (balanced flue)	-	30
C83x	Concentric connection to a moisture-resistant flue gas chimney and combustion air through an external wall (balanced flue)	Calculation to EN 13384 (LAS manufacturer)	
C93x	Flue for installation in a rigid or flexible duct DN 80 + 2m horizontal concentric connecting line	13	22

¹⁾ Available fan draught: 90 Pa
(The maximum length corresponds to the total length from the appliance to the flue terminal)

Note: Systems C 33x and C 83x are also suitable for installation in garages.
Where necessary, adapt the installation examples to the relevant Building Regulations and requirements of your country/region. Discuss any questions relating to the installation, particularly of inspection pieces and ventilation apertures (ventilation generally required above 50 kW output) prior to installation with your local heating engineer/ flue gas inspector.

The indicated lengths refer to either a concentric balanced flue or a flue in a duct and exclusively to original WOLF components.

Balanced flue systems DN60/100 and DN80/125 are certified as systems together with Wolf gas condensing boilers.

The following balanced flue or flues with CE-0036-CPD-9169003 certification may be used:

- Flue DN80
- Concentric balanced flue DN60/100 and DN80/125
- Flue DN110
- Concentric balanced flue (on an external wall) DN80/125
- Flue, flexible DN83

The necessary type plates are supplied with the respective WOLF accessory.

Observe all additional installation instructions included with accessories

Balanced flue routing for wall mounted gas fired boilers from 35 kW to 50 kW

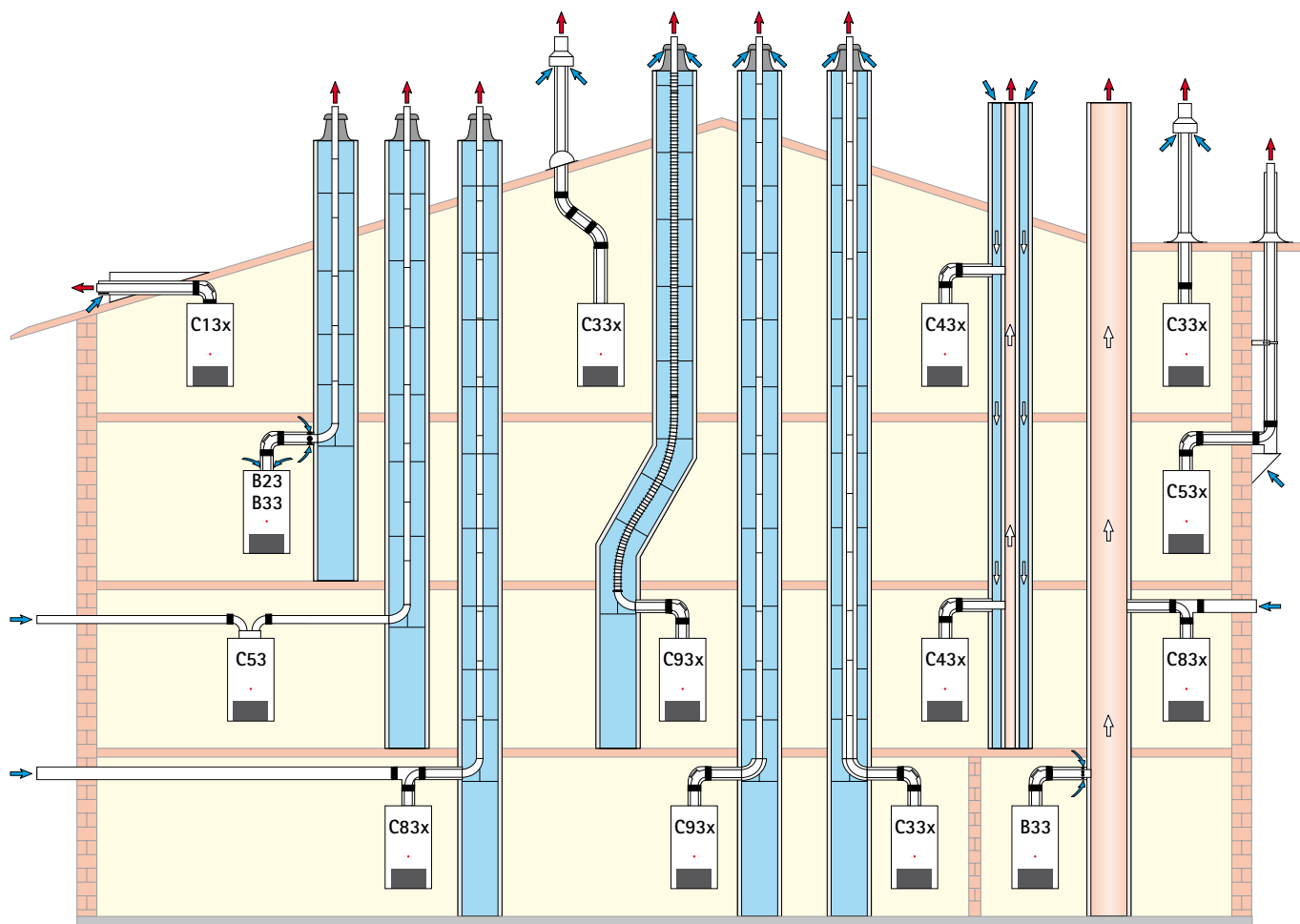

System versions			Maximum length ¹⁾ [m]		
			CGB-35	CGB-K40-35	CGB-50
B23	Flue pipe inside a duct and combustion air directly through the boiler (open flue)	DN80 DN110	30 35	20 28	20 28
B33	Flue pipe inside a duct with horizontal, concentric Connection line (open flue)	DN80 DN110	30 35	20 28	20 28
B33	Connection to a moisture-resistant flue gas chimney with horizontal concentric connection line (open flue)		Calculation to EN 13384 (LAS manufacturer)		
C13x	Horizontal roof outlet through a pitched roof (balanced flue)		20	11	11
C33x	Vertical concentric roof outlet through a pitched or flat roof, vertical concentric balanced flue routing for installation in a duct (balanced flue)		22	13	13
C43x	Connection to a moisture-resistant balanced flue chimney (LAS flue) maximum pipe length from the centre of the boiler bend to the connector 2 m (balanced flue)		Calculation to EN 13384 (LAS manufacturer)		
C53	Connection to a flue in a duct and ventilation air supply through an external wall (balanced flue)	DN80 DN110	30 35	20 28	20 28
C53x	Connection to a flue on an external wall (balanced flue)	DN80	22	15	15
C83x	Connection to a flue in a duct and ventilation air supply through an external wall (balanced flue)	DN80 DN110	30 35	20 28	20 28
C83x	Concentric connection to a moisture-resistant flue gas chimney and combustion air through an external wall (balanced flue)		Calculation to EN 13384 (LAS manufacturer)		
C93x	C33x Flue for installation in a rigid or flexible duct with horizontal concentric connecting line	DN80 DN110	22 30	15 22	15 22

¹⁾ Available fan draught:

CGB-35 115 Pa, CGB-50 145 Pa, CGB-K40-35 115 Pa

(The max. length corresponds to the total length from the boiler to the flue terminal.)

Note: System C 33x is also suitable for installation in garages.

Where necessary, adapt the installation examples to the relevant Building Regulations and requirements of your country/region. Discuss any questions relating to the installation of inspection covers and ventilation apertures with your local heating engineer.

To safeguard the optimum function we recommend that you use only original WOLF components for the concentric routing of balanced and conventional flues.

The following balanced flue or flues with CE-0036-CPD-9169003 certification may be used:

- Flue DN80
- Concentric balanced flue DN60/100 and DN80/125
- Flue DN110
- Concentric balanced flue (on an external wall) DN80/125
- Flue, flexible DN83

The necessary type plates are supplied with the respective WOLF accessory.

Observe all additional installation instructions included with accessories

Balanced flue routing for wall mounted gas fired boilers from 75 kW to 100 kW

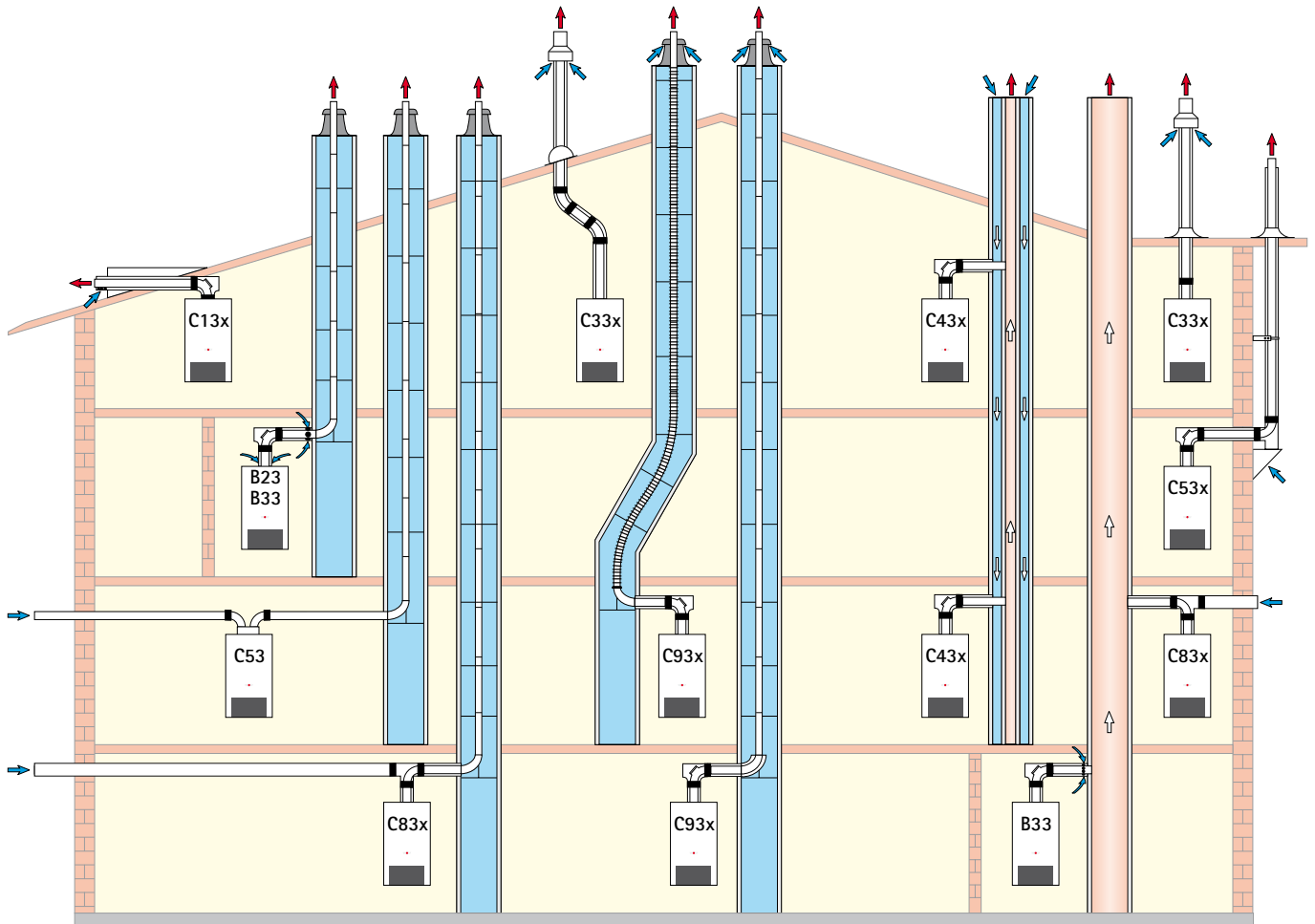

System versions		Maximum length ¹⁾ [m]		
		CGB-75	CGB-100	
B23	Flue pipe inside a duct and combustion air directly through the boiler (open flue)	DN110 DN110/160 ²⁾	23 50	23 50
B23	Two-party cascade, flue pipe inside a duct and combustion air directly through the boiler (open flue)	DN110	45	23
B33	Flue pipe inside a duct with horizontal, concentric Connection line (open flue)	DN110 DN110/160 ²⁾	23 50	23 50
B33	Connection to a moisture-resistant flue gas chimney with horizontal concentric connection line (open flue)		Calculation to EN 13384 (LAS manufacturer)	
C13x	Horizontal roof outlet through a pitched roof (balanced flue - on-site dormer)	DN110/160	14	14
C33x	Vertical concentric roof outlet through a pitched or flat roof, vertical concentric balanced flue routing for installation in a duct (balanced flue)	DN110/160	14	14
C43x	Connection to a moisture-resistant balanced flue chimney (LAS flue) maximum pipe length from the centre of the boiler bend to the connector 2 m (balanced flue)		Calculation to EN 13384 (LAS manufacturer)	
C53	Connection to a flue in a duct and ventilation air supply through an external wall (balanced flue)	DN110 DN110/160 ²⁾	23 50	23 50
C53x	Connection to a flue on an external wall (balanced flue)	DN110	15	15
C83x	Connection to a flue in a duct and ventilation air supply through an external wall (balanced flue)	DN110 DN110/160 ²⁾	23 50	23 50
C83x	Concentric connection to a moisture-resistant flue gas chimney and combustion air through an external wall (balanced flue)		Calculation to EN 13384 (LAS manufacturer)	
C93x	Flue for installation in a rigid or flexible duct with horizontal concentric connecting line	DN110 DN110/160 ²⁾	14 45	14 39

¹⁾ Available fan draught: CGB-75 145 Pa, CGB-100 200 Pa
(The max. length corresponds to the total length from the boiler to the flue terminal.)
²⁾ Expansion in the duct from DN110 to DN160

Note: Systems C 33x and C 83x are also suitable for installation in garages.
Where necessary, adapt the installation examples to the relevant Building Regulations and requirements of your country/region. Discuss any questions relating to the installation, particularly of inspection pieces and ventilation apertures (ventilation generally required above 50 kW output) prior to installation with your local heating engineer/ flue gas inspector.

The indicated lengths refer to either a concentric balanced flue or a flue in a duct and exclusively to original WOLF components.

The following balanced flue or flues with CE-0036-CPD-9169003 certification may be used:
- Flue DN110, 160 and 200
- Concentric balanced flue DN110/160, DN160/225 and DN200/300
- Concentric balanced flue (on an external wall) DN110/160
- Flue, flexible DN110
The necessary type plates are supplied with the respective WOLF accessory.
Observe all additional installation instructions included with accessories

Gas fired condensing boilers

ComfortLine

CGB Wall mounted gas fired condensing central heating boiler with optional connection of a DHW cylinder

CGB-K Wall mounted gas fired condensing boiler for DHW and central heating

CGW Wall mounted gas fired condensing boiler for DHW and central heating with wall mounted stainless steel stratification cylinder

CGS Gas fired condensing centre for DHW and central heating with enamelled steel stratification cylinder

CSZ Gas fired condensing solar centre in modular design for DHW and central heating

Tested in accordance with EC Directive and DIN EN 483 for heating systems to DIN EN 12828 with flow temperatures up to 90 °C and 3 bar permissible operating pressure. Suitable for modulating operation down to room temperature; modulating output control; automatic matching of the air factor to the balanced flue system; premix burner; equipped and adjusted in the factory for natural gas E, LL or LPG; sealed combustion chamber for open and balanced flue operation.

Control with gas burner control unit, electronic ignition and ionisation flame monitor; variable speed fan.

Powder-coated white (RAL 9016) casing.

	CGB 11 20 24	CGB 35 50 75 100	CGB mit CSW 120	CGB-K 20 24	CGB-K 40-35	CGW 11/100 20/120 24/140	CGS 20/160 24/200	CSZ 11/300 20/300 24/300
Accessories								
Control accessories								
BM programming module	○	○	○	○	○	○	○	●
Wall mounting base	○	○	○	○	○	○	○	○
Analogue remote control AFB	○	○	○	○	○	○	○	○
MM mixer module	○	○	○	○	○	○	○	○
Solar module SM1	○	○	○	○	○	○	○	●
Solar module SM2	○	○	○	○	○	○	○	
KM Cascade module	○	○						
Calorimeter kit for yield measurement	○	○	○	○	○	○	○	○
Radio clock with outside temperature sensor	○	○	○	○	○	○	○	○
Radio clock for automatic time adjustment	○	○	○	○	○	○	○	○
Wireless receiver - required for external wireless sensor and wireless remote control	○	○	○	○	○	○	○	○
ISM 4 - LON interface module	○	○	○	○	○	○	○	○
WRS-Remote service system	○	○	○	○	○	○	○	○
Telecontrol module	○	○	○	○	○	○	○	○
Hydraulic accessories and gas supply accessories								
Gas ball valve (angle/straight-through version), chrome-plated, with/without thermally activated shut-off valve	○	○	○	○	○	○	○	●
Safety valve Rp 1/2" up to 3 bar, chrome plated	○	○	○	○	○	○	○	●
Drain outlet kit R1" with siphon and bezel, grey plastic	○	○	○	○	○	○	○	●
Accessories for installation on unfinished walls								
Angle maintenance valve G 3/4", chrome plated	○		○	○		○	○	
Angle maintenance valve G 3/4" with connection R 1/2" for safety valve, chrome plated	○		○	○		○	○	
DHW connector G 1/2", chrome plated				○		○		
Cold water connector G 1/2", chrome plated	○			○		○		
Connection set for installation on unfinished walls	○		○	○		○	○	
DHW connection set with or without pressure reducer						○		

Gas fired condensing boilers ComfortLine

	CGB 11 20 24	CGB 35 50 75 100	CGB mit CSW 120	CGB-K 20 24	CGB-K 40-35	CGW 11/100 20/120 24/140	CGS 20/160 24/200	CSZ 11/300 20/300 24/300
Accessories for installation on finished walls								
Straight-through maintenance valve Rp 3/4", chrome-plated	○		○	○		○	○	
Straight-through maintenance valve Rp 3/4" with connection R 1/2" for safety valve, chromeplated	○		○	○		○	○	
DHW connector R 1/2", chrome plated				○		○		
Cold water connector R 1/2", chrome plated				○		○		
Connection set for installation on finished walls	○		○	○		○	○	
Preassembled connection set for finished walls							○	
Heating circuit connection set		○			○			
Low loss header set with complete pipework and insulation for 1 or 2 boilers		○ only for CGB- 75/100						
DHW connection set with or without pressure reducer						○		
Accessories connection sets								
Solar heating connection set for the additional control of a solar cylinder						○	○	
Connection set for pipework of gas fired condensing centre to heating flow/return, DHW/cold water, gas partly preassembled							○	
Connection set flow and return for heating and solar circuit and gas connection								○
Connection set DHW/cold water, with thermostatic mixer and highly efficient DHW circulation pump								○
Accessories for circulation								
DHW circulation set to EnEV incl. DHW circulation pump with analog time switch		○				○	○	
DHW circulation set to EnEV incl. DHW circulation pump with digital time switch		○				○	○	
Highly efficient DHW circulation pump								○
Further accessories								
Pipe cover		○				○	○	
Casing for boiler top							○	
Adjustable base for unfinished floor								○
Current anode							○	○
Calorimeter kit								○
DHW cylinder CSW-120	○							
Balanced flue accessories								
Concentric balanced flue system	○	○	○	○	○	○	○	○
External wall system	○	○	○	○	○	○	○	○
Connection set for flues in a duct	○	○	○	○	○	○	○	○

- included in delivery
- possible accessories

Contact in New Zealand:



65 Happy Valley Road, Owhiro Bay
Wellington 6023

(04) 977 56 51

e-mail: info@ecoheatingandplumbing.co.nz

web: www.ecoheatingandplumbing.co.nz

Heating & Plumbing (NZ) Ltd.

System example: New build

Central heating system components:

- ComfortLine wall mounted gas fired condensing boiler, CGB-20

Solar system components:

- Flat-panel collector, TopSon F3
- Stratification cylinder, BSP

Ventilation system components:

- Domestic ventilation equipment, KWL-260

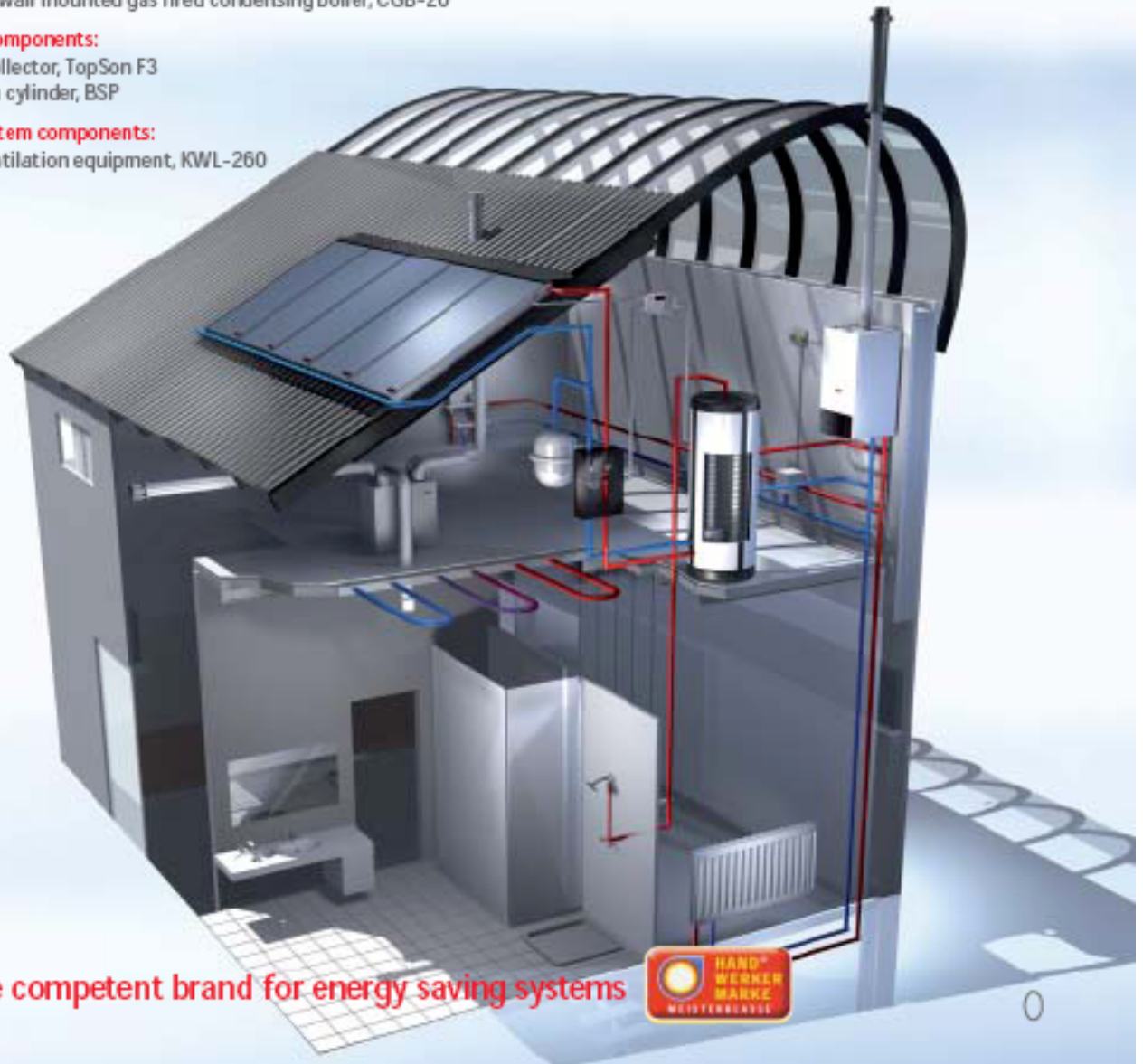

The competent brand for energy saving systems

