

ELECTRIC HORIZONTAL WARM WATER HEATER



Electric horizontal
warm water heater



EKL



AE
Austria Email

Electric horizontal warm water heater

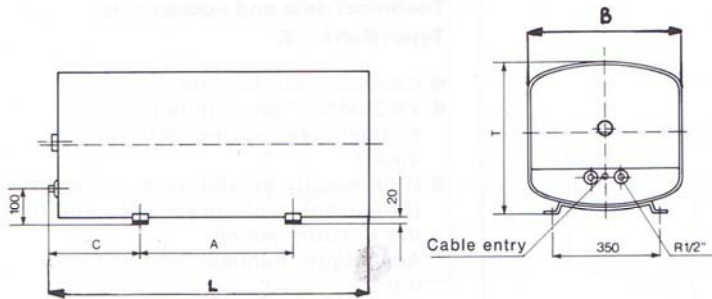

Wall bracket for electric horizontal warm water heater

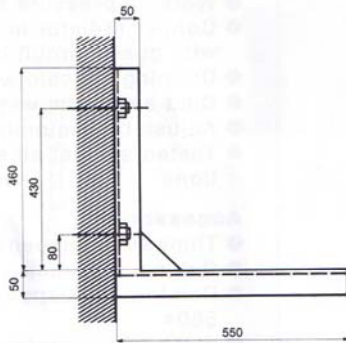

Electric Horizontal Warm Water Heaters

Technical data and accessories

Type: EKL

- Capacity: 80, 100, 120, 150, 180, 200 l
- VACUMAIL® inner tank of double enamel layer system with rod anode
- High-quality insulation of PU-foam (CFC-free), tank directly foamed in the outside casing
Advantage: minimal heat abstraction!
- Static powder coated steel sheet casing
- Universal circuit
- Infinitely temperature control from 40°C to 85°C
- 65°C energy saving setting
- Anti-freeze setting at about 8°C
- Multi-purpose capillary tube control system with multi phase thermal security limiter
- Working pressure max. 6 bar
- Copper radiator insulated – built-in with guard circuit bleeder resistor
- Draining via cold water tube
- Cold and warm water supply RG 1/2"
- Tested against all standard regulations

Accessories:

- Wall bracket 6910
- Stone screws ST-SCHR
- DL-SVRV flow safety valve- and check valve 3/4", 6 bar

Type	Nominal Capacity in Litres	Adjustable Heating Time in kW						Dimensions in mm					Empty Weight in kg	Stand-by Energy Consumption kWhrs./24 hrs.	
		~ 220 V AC			3 ~ 380 V AC			Length	B	T	C	A			
8 hrs.	6 hrs.	4 hrs.	3 1/2 hrs.	4 hrs.	3 1/2 hrs.	3N~380VAC 3 1/2 hrs.									
EKL 80U	80	1,00	1,65	2,0	2,65		2,5		780	480	480	150	500	42	1,15
EKL 100U	100	1,10	1,75	2,2	2,85		2,7		1054	480	480	300	500	52	1,25
EKL 120U	120	1,30	1,95	2,6	3,25		3,0		1059	520	520	300	500	61	1,29
EKL 150U	150	1,65	2,30	3,3			3,6	3,95	1253	520	520	300	700	66	1,52
EKL 180U	180	2,00	2,65				4,1	4,65	1446	520	520	300	800	73	1,69
EKL 200U	200	2,10	2,75				4,2	4,9	1546	520	520	300	1000	77	1,84

All appliances are adjusted for 6 hours heating time ex works